

# RULES OF CAMERA-READY MANUSCRIPT PREPARATION FOR THE CONFERENCE SICPRO '12

K.R. Chernyshov

*V.A. Trapeznikov Institute of Control Sciences*  
65 Profsoyuznaya, Moscow 117997, Russia

E-mail: [noc@sicpro.org](mailto:noc@sicpro.org)

N.P. Surname of the co-author

*Affiliation*

House No, Street, City POSTAL ZIP, Country

E-mail:     @    

**Ключевые слова:** system identification, control problems, SICPRO '12, paper preparation, conference proceedings, author guideline

lease read carefully the rules of camera-ready manuscript preparation for Proceedings of the international conference of "System Identification and Control Problems" to be CD-ROM published. Exact following the rules is of extreme importance to provide professional quality of the Proceedings. The Organizing Committee is in advance obliged to authors for following the rules. Simultaneously, the Organizing Committee has to point out that manuscripts, which do not meet the rules, will not be included into the Proceedings of SICPRO '12.

## 1. Introduction

Manuscripts for the Conference SICPRO '12 Proceedings should be submitted as Word (for MS Windows) files whose names are to be the registration number of the manuscript which was given to authors by the Organizing Committee (in case of using LATEX) please refer to the corresponding style file in accordance to the information available at the conference site <http://www.sicpro.org> (please select a corresponding submenu therein)). In case of a large volume of a source file, it is possible to use ARJ for MS DOS or ZIP for MS Windows, and the name of the file should be the same as the initial one. The dead line for submitting manuscripts is July 01, 2011.

If there are co-authors, after the e-mail address of the first author leave one blank line and type other organizations and addresses in the same order. Please follow these instructions by indicating the second and other authors, their organization and addresses, even if the authors represent the same organization! If the list of the authors (by a large number of co-authors) does not find room on the first page, it proceeds on the second page of the manuscript.

The author defines the number of key words. If the list of key words (by a large number of co-authors) does not find room on the first page, it proceeds on the second page of the manuscript in the same format.

If the abstract (by a large number of co-authors) does not find room on the first page, it proceeds in the same format on the second page of the manuscript.

## 2. The main text preparation

### 2.1. General rules

The paper length should be not less than 7 (SEVEN) pages (mandatory condition).

### 2.2. Headings of sections (Headings of the first and second levels)

The authors may divide the main text of the manuscript into sections. Numbering of the sections should be Arabic, beginning from 1, then put a point and leave a blank. The section heading should be with an initial capital. After the heading no point or any other signs should be put.

If necessary, headings of the first and second levels can take two and more lines (centered).

### 2.3. Further partition of the text

**2.3.1. Headings of the first and second levels.** The authors may divide the main text of the manuscript into sections. Numbering of the sections should be Arabic, beginning from 1, then put a point and leave a blank. The section heading should be with an initial capital. After the heading no point or any other signs should be put.

If necessary, headings of the first and second levels can take two and more lines (centered).

### 2.4. Further partition of the text

**2.4.1. Headings of the third level.** If necessary it is possible to divide the text. In this case subsection is divided into items with appropriate heading of the third level.

### 2.5. Appearance of theorems, definitions, etc.

Let us introduce the following definition.

**Definition 1.** *XXXXXXXXXXXXXXXXXXXX XXXXX-XXXXXXXX X XXXXX XXXXXXXXXXXX XXX XXXXXXXX  
XXX. XXXX XXXXXXXX XXXXXXXXXXXXXXXXXXXX X XXXXX.*

XXXX XXXXXXXX XXXXXXXXXXXXXXXXXXXX X XXXXX XXXXXXXXXXXX XXX XXXXXXXX XXXX.

Consider the following problem.

**Задача 1.** *XXXXX XXXXXXXX XXXXXXX XXXXXXXXXXXX X XXXXX XXXXXXXXXXXX XXX XXXXXXXX  
XXX. XXXX XXXXXXXX XXXXXXXXXXXXXXXXXXXX X XXXXXXXXXXXX X XXXXX.*

XXXXXXX XXXXXXXXXXXX XXXXXXX XXXXXXXXXXXX X XXXXX XXXXXXXXXXXX XXX XXXXXXXX XXXX.

XXXXXX XXXXXXXXXXXX XXXXXXXXXXXXXXXXXXXX X XXXXXXXXXXXX X XXXXX.

**Theorem 1.** *XXXXXXXXXXXXXXXXXXXX-XXXXXXXXXXXX XXXXX XXXXXXXXXXXXXXX XXXXXXXXXXXXXXX  
XXXX. XXXXX XXXXXXXXXXXXXXX XXXXXXXXXXXXXXX XXXXX.*

*Proof of Theorem 1.* XXXXXXXXXXXXXXXXXXXXXXX XXXXXXX-XXXXXXXXXXXX X XXXXX XXXXXXXXXXXXXXX  
XXX XXXXXXX XXXX. XXXXX XXXXXXXXXXXXXXX XXXXXXXXXXXXXXX XXXXX.

### 3. Formulas, their disposition and numbering

An example of organizing a non-numbered formula:

$$G(s) = A(s)B(s), \quad A(s) = a_0 + a_1s + \dots + a_ms^m,$$

$$B(s) = b_0 + b_1s + \dots + b_ns^n, \quad m \leq n.$$

An example of organizing a numbered formula:

(1)  $\dot{x} = Ax + Bu, \quad y = Cx,$

### 4. Figures and tables, their disposition and numbering

Figures should be numbered as follows: Fig. 1, Fig. 2, and etc. By reference to the figure you should always use the reduction "fig.". The figures are numbered sequentially, Arabic, beginning from 1.

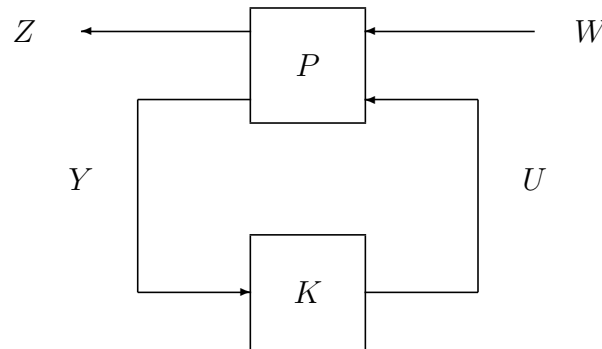

**Fig. 1.** An example of a figure disposition

Tables should be numbered as follows: Table 1, Table 2, ... etc. The tables should be numbered sequentially, in the order they were mentioned, Arabic, beginning from 1. Leave one blank line between a word "Table" and the following paragraph.

**Table 1.** An example of a table disposition

$a$	$F_a$	$a$	$F_a$	$a$	$F_a$
0	0.4730	0.1	0.5800	2	0.9161
0.01	0.5064	0.2	0.6254	3	0.9751
0.02	0.5204	0.3	0.6597	4	1.0091
0.03	0.5313	0.4	0.6886	5	1.0291
0.04	0.5404	0.5	0.7137	6	1.0410
0.05	0.5483	0.6	0.7362	7	1.0482
0.06	0.5555	0.7	0.7564	8	1.0525
0.07	0.5622	0.8	0.7748	9	1.0551
0.08	0.5689	0.9	0.7917	10	1.0567
0.09	0.5745	1	0.8074	11	1.0576

## References

1. Abelson H., Eisenberg M., Halfant M., Katznelson J., Sackes E., Sussman G., Wislom J., Yip K. Intelligence in scientific computing // Commun. ACM. 1989. Vol. 32. No 5. P. 546-561.
2. Billings S.A., Fadzil M.B., Sulley J., Johnson P.M. Identification of a non-linear difference equation model of an industrial diesel generator // Mechanical Systems and Signal Processing. 1988. Vol. 2, No 1. P. 59-76.
3. Booton R.C. Nonlinear control systems with random inputs // Trans. IRE Profes. Group on Circuit Theory. 1954. Vol. CT1, No 1. P. 9-18.
4. Boyd S., Chua L.O. Fading memory and the problem of approximating nonlinear operators with Volterra series // IEEE Trans. Circuits Syst. 1985. Vol. CAS-32, No 11. P. 1150-1161.
5. Freedman R.S., Tuzin G.J. A knowledge-based methodology for tuning analytical models // IEEE Trans. Syst. Man Cybern. 1991. Vol. SMC-21. No 3. P. 347-358.
6. Blackwell D., Girshick M. Theory of Games and Statistical Decision. New York: Wiley, 1954.
7. Beaman J.J. Accuracy of statistical linearization // New approaches to nonlinear problems in dynamics / Ed. by P.J. Holmes. Philadelphia, Pa: Society for Industrial and Applied Mathematics, 1980. P. 195-207.
8. Sawchuk A.A., Strand T.C. Fourier optics in nonlinear image processing // Applications of Optical Fourier Transforms / Ed. by H. Stark. New York: Academic, 1982. P. 371-429.
9. LAM/MPI Parallel Computing. <http://www.osc.edu/lam.html>.