

# RULES OF CAMERA-READY MANUSCRIPT PREPARATION FOR THE CONFERENCE SICPRO '08

K.R. Chernyshov  
*Institute of Control Sciences*  
65 Profsoyuznaya, Moscow 117997, Russia  
E-mail: [myau@ipu.rssi.ru](mailto:myau@ipu.rssi.ru)

N.P. Surname (of the co-author)  
*Organization*  
House No, Street, City POSTAL ZIP, Country  
E-mail:     @    

**Key word:** system identification, control problems, SICPRO '08, paper preparation, conference proceedings, author guideline

Please read carefully the rules of camera-ready manuscript preparation for Proceedings of the international conference of "System Identification and Control Problems" to be CD-ROM published. Exact following the rules is of extreme importance to provide professional quality of the Proceedings. The Organizing Committee is in advance obliged to authors for following the rules. Simultaneously, the Organizing Committee has to point out that manuscripts, which do not meet the rules, will not be included into the Proceedings of SICPRO '08.

## 1. Introduction

The camera-ready papers intended to the SICPRO '08 Proceedings are to be submitted either in the MS Word (version 6.0 or higher) format or in the format of LaTeX (in that case, a paper is to be submitted as tex- AND dvi- AND pdf- files, as well as accompanied with separate files of the paper figures (in case of involving the figures into the paper code as separate files). In case of a large volume of a source file, it is possible to use ARJ for MS DOS or ZIP for MS Windows, and the name of the file should be the same as the initial one. The dead line for submitting manuscripts is July 31, 2007.

## 2. The main text preparation

### 2.1. General rules

Volume of the manuscript is not limited, but the organizing Committee asks the authors to be guided by a principle "of reasonable sufficiency".

## 2.2. Headings of sections (Headings of the first and second levels)

The authors may divide the main text of the manuscript into sections. Numbering of the sections should be Arabic, beginning from 1, then put a point and leave a blank. The section heading should be with an initial capital. After the heading no point or any other signs should be put.

If necessary, headings of the first and second levels can take two and more lines (centered).

## 2.3. Further partition of the text

**2.3.1. Headings of the third level.** If necessary it is possible to divide the text. In this case subsection is divided into items with appropriate heading of the third level.

## 2.4. Appearance of theorems, definitions, etc.

Let us introduce the following definition.

*Definition 1.* XXXXXXXXXXXXXXXXXXXX XXXXXX-XXXXXXXXX X XXXXX XXXXXXXXXXXX XXX XXXXXXXXXXX XXXX. XXXXXX XXXXXXXXXXX XXXXXXXXXXXXXXXXXXXX X XXXXX.

XXXX XXXXXXXXXXX XXXXXXXXXXXXXXXXXXXX X XXXXX XXXXXXXXXXX XXX XXXXXXXXXXX XXXX.

Consider the following problem.

*Problem 1.* XXXXXX XXXXXXXXXXX XXXXXX XXXXXXXXXXX X XXXXX XXXXXXXXXXX XXX XXXXXXXXXXX XXXX. XXXXXX XXXXXXXXXXX XXXXXXXXXXXXXXXXXXXX X XXXXXXXXXXX X XXXXX.

XXXXXXXX XXXXXXXXXXX XXXXXX XXXXXXXXXXX X XXXXX XXXXXXXXXXX XXX XXXXXXXXXXX XXXX. XXXXXX XXXXXXXXXXX XXXXXXXXXXXXXXXXXXXX X XXXXXXXXXXX X XXXXX.

*Theorem 1.* XXXXXXXXXXXXXXXXXXXX XXXXXX-XXXXXXXXX X XXXXX XXXXXXXXXXX XXX XXXXXXXXXXX XXXX. XXXXXX XXXXXXXXXXX XXXXXXXXXXXXXXXXXXXX X XXXXX.

*Proof of Theorem 1.* XXXXXXXXXXXXXXXXXXXX XXXXXX-XXXXXXXXX X XXXXX XXXXXXXXXXX XXX XXXXXXXXXXX XXXX. XXXXXX XXXXXXXXXXX XXXXXXXXXXXXXXXXXXXX X XXXXX.

## 3. Formulas, their disposition and numbering

An example of organizing a non-numbered formula:

$$G(s) = A(s)B(s), \quad A(s) = a_0 + a_1s + \dots + a_ms^m,$$

$$B(s) = b_0 + b_1s + \dots + b_ns^n, \quad m \leq n.$$

An example of organizing a numbered formula:

$$(1) \quad \dot{x} = Ax + Bu, \quad y = Cx,$$

## 4. Figures and tables, their disposition and numbering

Figures should be numbered as follows: Fig. 1, Fig. 2, and etc. By reference to the figure you should always use the reduction "fig.". The figures are numbered sequentially, Arabic, beginning from 1.

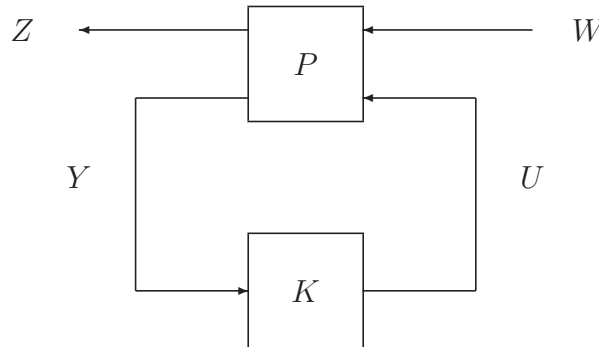

**Fig. 1.** An example of a figure disposition

Tables should be numbered as follows: Table 1, Table 2, ... etc. The tables should be numbered sequentially, in the order they were mentioned, Arabic, beginning from 1. Leave one blank line between a word "Table" and the following paragraph.

**Table 1.** An example of a table disposition

| $a$  | $F_a$  | $a$ | $F_a$  | $a$ | $F_a$  |
|------|--------|-----|--------|-----|--------|
| 0    | 0.4730 | 0.1 | 0.5800 | 2   | 0.9161 |
| 0.01 | 0.5064 | 0.2 | 0.6254 | 3   | 0.9751 |
| 0.02 | 0.5204 | 0.3 | 0.6597 | 4   | 1.0091 |
| 0.03 | 0.5313 | 0.4 | 0.6886 | 5   | 1.0291 |
| 0.04 | 0.5404 | 0.5 | 0.7137 | 6   | 1.0410 |
| 0.05 | 0.5483 | 0.6 | 0.7362 | 7   | 1.0482 |
| 0.06 | 0.5555 | 0.7 | 0.7564 | 8   | 1.0525 |
| 0.07 | 0.5622 | 0.8 | 0.7748 | 9   | 1.0551 |
| 0.08 | 0.5689 | 0.9 | 0.7917 | 10  | 1.0567 |
| 0.09 | 0.5745 | 1   | 0.8074 | 11  | 1.0576 |

## References

1. Abelson H., Eisenberg M., Halfant M., Katznelson J., Sackes E., Sussman G., Wislom J., Yip K. Intelligence in scientific computing // Commun. ACM. 1989. Vol. 32. No 5. P. 546-561.
2. Billings S.A., Fadzil M.B., Sulley J., Johnson P.M. Identification of a non-linear difference equation model of an industrial diesel generator // Mechanical Systems and Signal Processing. 1988. Vol. 2, No 1. P. 59-76.

3. Booton R.C. Nonlinear control systems with random inputs // Trans. IRE Profes. Group on Cir-cuit Theory. 1954. Vol. CT1, No 1. P. 9-18.
4. Boyd S., Chua L.O. Fading memory and the problem of approximating nonlinear operators with Voltterra series // IEEE Trans. Circuits Syst. 1985. Vol. CAS-32, No 11. P. 1150-1161.
5. Freedman R.S., Tuzin G.J. A knowledge-based methodology for tuning analytical models // IEEE Trans. Syst. Man Cybern. 1991. Vol. SMC-21. No 3. P. 347-358.
6. Blackwell D., Girshick M. Theory of Games and Statistical Decision. New York: Wiley, 1954.
7. Beaman J.J. Accuracy of statistical linearization // New approaches to nonlinear problems in dy-namics / Ed. by P.J. Holmes. Philadelphia, Pa: Society for Industrial and Applied Mathematics, 1980. P. 195-207.
8. Sawchuk A.A., Strand T.C. Fourier optics in nonlinear image processing // Applications of Opti-cal Fourier Transforms / Ed. by H. Stark. New York: Academic, 1982. P. 371-429.
9. LAM/MPI Parallel Computing. <http://www.osc.edu/lam.html>.